

# SWIT®

PB-M98S、M45S

Rechargeable Li-ion Battery

Ver:A

# USER MANUAL

SWIT Electronics Co.,Ltd.

Tel:+86-25-85805753  
Fax:+86-25-85805296  
<http://www.swit.cc>  
E-mail: [contact@swit.cc](mailto:contact@swit.cc)

Congratulations on your purchase of this product. Please read this user manual carefully.

## ⚠ Warning

Keep in mind the following precautions to avoid fire and other safety hazards !

- Do not use battery in fire or hot places to prevent overheating, cracking and other hazards.
- Please do not pierce the battery shell or try to open the shell and decompose the battery.
- Do not use battery beyond charge, discharge and storage environment temperature.
- Do not charge the battery in the car or in direct sunlight.
- Do not use damaged battery.
- Do not squeeze the battery shell which may cause physical damage.
- Make sure the power-consuming equipment(s) meet the battery specifications.
- Use SWIT charger or SWIT recommended charger to charge the battery to avoid overheating or cracking.
- Keep out of the reach of children.

## Description of appearance

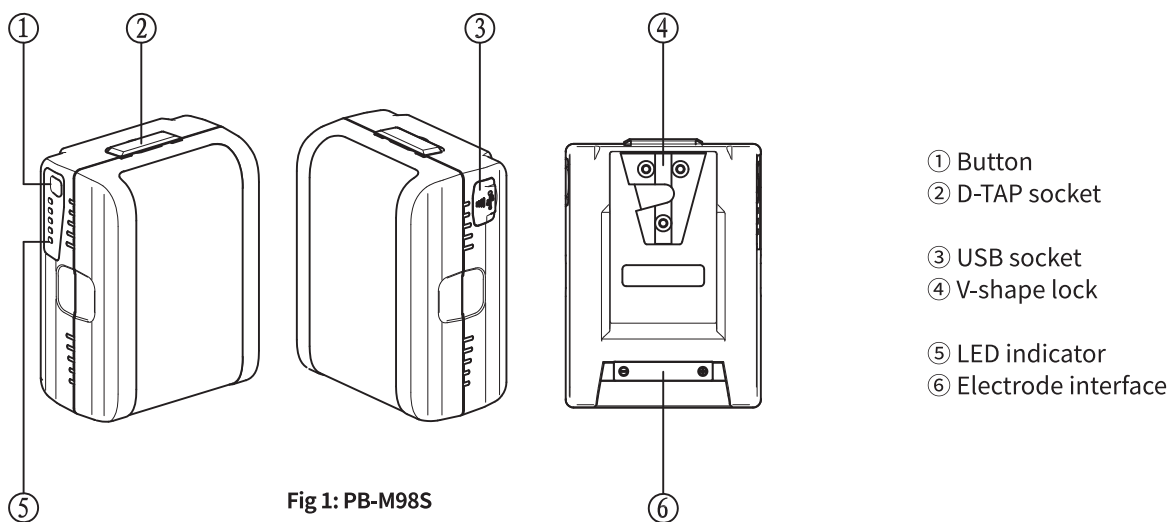

## Caution

- Fully charged battery will discharge naturally and please use it as soon as it gets charged.
- The battery may become warm in use or while being charged. This is normal.
- Never expose the battery to temperature above 60°C.
- Keep the battery terminals clean and never short-circuit the battery terminals.
- When stored for a long time, please keep the battery power over 50%.
- After ten days' standing, the battery will automatically enter into the sleep mode, and the output will be shut off. Press the button to restore the output.

## Features

- High performance rechargeable lithiumion battery, no memory effect.
- LED display remaining power percentage in real time.
- Built-in multiple control circuit, to protect the battery in round from temperature, voltage and current.
- D-tap DC output, to power the camera and other equipment simultaneously.
- USB 5V/2A output, which can be used to charge mobile phones, tablets and other portable devices.

## Charging

- The battery can be charged at a temperature range of 0~40°C, but it is suggested to charge at a temperature range of 10°C~30°C for the best performance of the battery.

## Discharging

- The battery can discharge at a temperature range of -20°C~50°C, but it is suggested to discharge at a temperature range of -10~40°C for the best performance of the battery.
- Press the button to turn on the USB output for use. When the battery power is below 10%, the lowest LED flashes and the USB is not available at this time.
- At low temperature, the battery internal resistance will increase, and the discharging time will shorten, which may lead to automatically cut off if the load is heavy.
- The USB output will shut off if the load is too heavy, and press the button to restore.

## Specification

Model	PB-M98S	PB-M45S	
Battery plate	V-mount	V-mount	
Nominal voltage	14.4V	14.4V	
Capacity	98Wh,6.8Ah	45Wh,3.1Ah	
Max output	Electrodes	150W,12A	150W,12A
	D-TAP ×1	100W,8A	100W,8A
	USB ×1	10W,5V/2A	10W,5V/2A
	In total	150W	150W
Charging temperature	0~40°C (10~30°C recommended)		
Discharging temperature	-20°C~50°C (-10~40°C recommended)		
Dimension (mm)	100×74×48	100×74×34	
Net weight	0.51kg	0.31 kg	
Max charging current	3A	3A	

## LED display

- LED indicators from E to F represent power percentage 20%, 40%, 60%, 80% and 95% respectively.
- The following are several special statuses:

Power percentage	F → E
≥95%	●●●●●●
80%~95%	☀●●●●●
60%~80%	○☀●●●●
40%~60%	○○☀●●●
20%~40%	○○○☀●●
<20%	○○○○☀

<p>F → E</p> <p>☀☀○○○</p>	<p>The battery runs out of power or is protected. Please wait for some time to see the indicators status. If it is restored to the power percentage, it has been restored. If it is still in this status, the battery runs out of power. Please charge the battery asap.</p>
<p>F → E</p> <p>○○○☀☀</p>	<p>Over-current, over-temperature, or over-voltage when charging. Over-current, please remove the battery and wait for the battery to restore. Over-temperature, please put the battery in a cool place, and it will restore after 10 minutes' standing. Over-voltage, please remove the battery and discharge it to reduce the battery voltage to restore.</p>
<p>F → E</p> <p>☀☀○☀☀</p>	<p>The battery can not be charged or discharged. Please put the battery in a cool place to wait for the temperature of the battery chip to decrease(&gt;30mins is recommended). Then put the battery on the charger and try to charge it. If it is charged normally, the battery will restore to normal, otherwise please return the battery to repair it.</p>