

# SWIT®

SWIT ELECTRONICS CO., LTD.

Model: FLOW10K Tx / FLOW10K Rx  
10000ft/3km Wireless

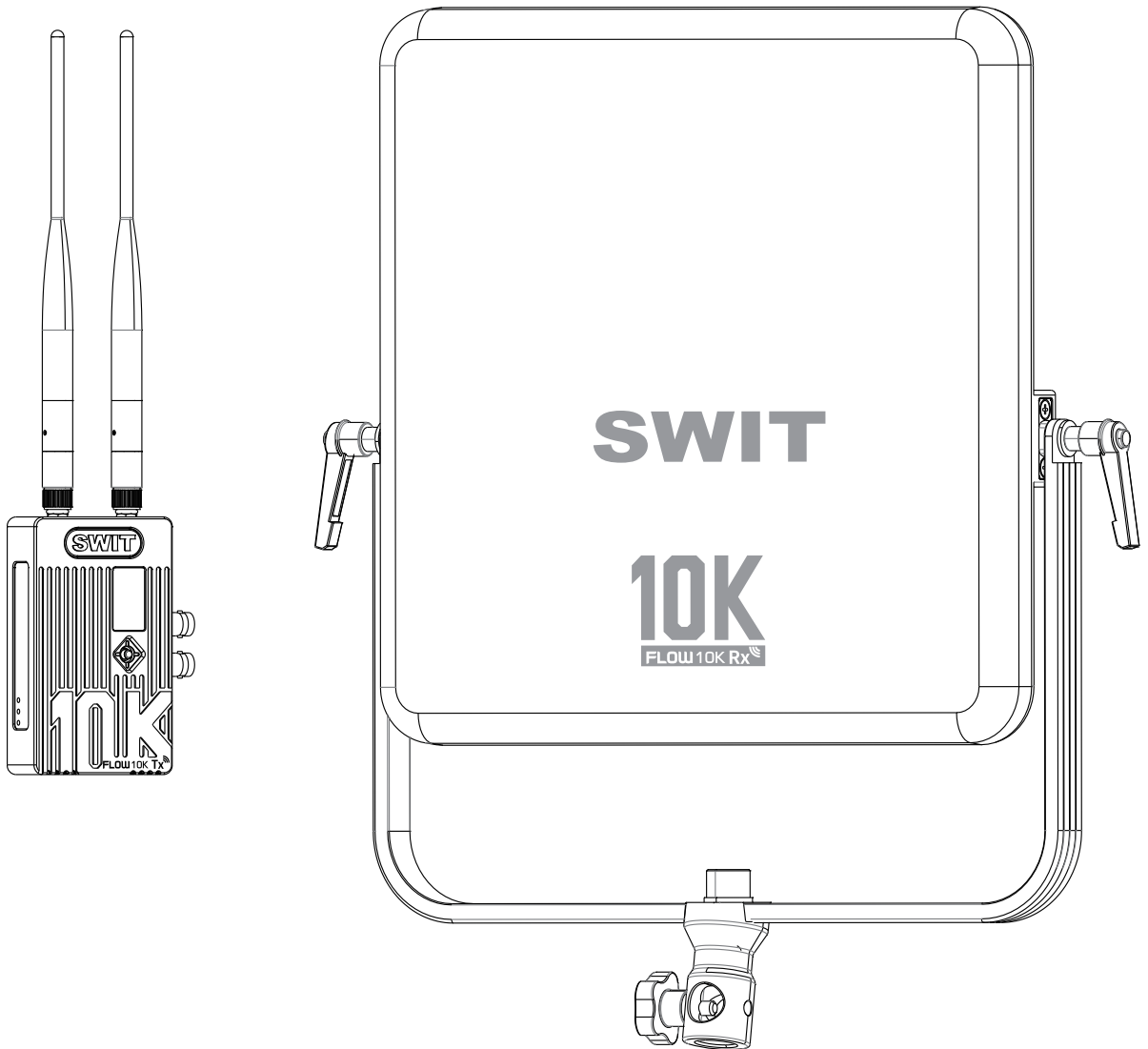

## User Manual

Please read this user manual throughout before using

Ver:A

## Preface

All internal technologies of this product are protected, including device, software and trademark. Reproduction in whole or in part without written permission is prohibited.

All brands and trademarks of SWIT Electronics Co., Ltd. are protected and other relative trademarks in this user manual are the property of their respective owners.

Due to constant effort of product development, SWIT reserves the right to make changes and improvements to the product described in this manual without prior notice.

The warranty period of this product is one years, and does not cover the following:

- (1) Physical damage to the products
- (2) Any damage or breakdown caused by use, maintenance, or storage not according to the user manual' s introductions.
- (3) The attenuation of signal quality resulting from being used in any special environments.
- (4) Any damage caused by not powering the product by package supplied power adaptor.
- (5) Any damage or breakdown not caused by the product' s design, workmanship, manufacturing, quality, or unauthorized repairs or parts replacement or other operations.

For any suggestions and requirements on this products, please contact us through phone, fax, Email, etc.

### **SWIT Electronics Co., Ltd.**

---

Address: 10 Hengtong Road, Nanjing Economic and Technological Development Zone,  
Nanjing 210038, P.R.China

Phone: +86-25-85805753

Fax: +86-25-85805296

Email: [contact@swit.cc](mailto:contact@swit.cc)

<http://www.swit.cc>

# Safety Precautions

Please follow the safety precautions before using. The following conditions are not covered by warranty.

1. Unauthorized repairs or other Unauthorized operations.
2. Inappropriate placement including but not limited to lighting, fire, exposure to rain, water or gas.
3. Using the wrong power supply.

## Warning

- Do not get any liquid inside the products
- Do not block the ventilation openings or put substances inside, in order to avoid short circuit, fire or electric shock.
- Do not place the product in the rain or moisture to avoid electric shock or fire.

## Danger

- Switch the power off before connecting other devices.
- Power socket: Make sure the power socket under the voltage range of the product to avoid short circuit, electric shock and fire.
- Power cable: Make sure the power cable is not pressed or tightened by any items or weights.
- Power Load: Do not exceed the load on the wall outlet, extension cable or other porous receptacle to avoid fire or electric shock.
- Lightning: Disconnect the power cable if it is lightning or not using in a long period of time.

## Working environment

- Please don't lay the product on any unstable place to avoid fallen damage.
- Please don't use the product in a place overheating, undercooling or with lots of moisture, or near by strong magnetic devices.
- Please don't lay the product on metal shelf, in order to ensure the effective wireless transmission.

## Packing list

No.	Packing details	Quantity
1	Transmitter	x 1
2	Receiver	x 1
3	Antenna	x 2
4	D-tap to lockable pole cable (0.6m)	x 1
5	Power adaptor	x 1
6	User manual	x 1
7	Warranty card	x 1
8	Articulating arm trestle	x 1

## 1. Product Introduction

FLOW10K includes transmitter and receive, adopts the latest encrypted transmission technology, Wireless transmission of HD-SDI and HDMI audio and video signals, dual SDI/HDMI digital audio transmission, Automatic pairing connection, auto and manual frequency choose, equipped with DC power connector. Supports HDMI&SDI signal wirelessly transmitted in 3000 meters scale(Line-of-sight), stable signal quality, Can be used in broadcast live program production, film and television crew director monitoring and other professional video field.

## 2. Features

### ◎ 3G/HD/SD-SDI & HDMI wireless transmission

Support up to 1080P50/60Hz HD-SDI/HDMI Audio and video wireless transmission.

### ◎ 3000 meters transmission distance

In open outdoor area, the effective transmission distance is approx. 3000 meters (line of sight).

### ◎ Wireless frequency

The system adopts 5180~5220MHz and 5760~5820MHz Wireless frequency band (FLOW10K Tx) .

Frequency Band and Frequency point			
CH00	5180MHz	CH04	5780MHz
CH01	5200MHz	CH05	5800MHz
CH02	5220MHz	CH06	5820MHz
CH03	5760MHz	/	/

The system adopts 5182.5~5282.5MHz and 5762.5~5822.5MHz Wireless frequency band (FLOW10K Rx) .

Frequency Band and Frequency point			
CH00	5182.5MHz	CH04	5782.5MHz
CH01	5202.5MHz	CH05	5802.5MHz
CH02	5222.5MHz	CH06	5822.5MHz
CH03	5762.5MHz	/	/

### ◎ Connection mode

Support auto pairing connection & manual switching of frequency points & Multicast - 1 transmitter to unlimited receivers.

### ◎ OLED information display

Display current transmission signal format, wireless channel, signal strength and other working status and working parameters.

### ◎ High quality & Wall through mode

Support 1 transmitter to unlimited receivers and High quality & Wall through mode choose.

### ◎ Encryption

Support AES 128-bit encryption to protect the transmission.

### ◎ All-Metal Shell

Both the transmitter and receiver adopt metal shell which is durable and solid.

### ◎ All hardware design

The wireless system is hardware and plug-and-play designed, without installing software, easy to set up.

### ◎ Multiple battery plates change

Transmitter can choose different battery plate according to demand.

### Remark:

1. The transmission distance may be different, and depending on surroundings, radio wave conditions, buildings, etc., the 3000 meters transmission distance may be not guaranteed in a complex environment.
2. The wireless transmission might be interrupted if there' re other devices of 5Ghz wireless bandwidth used in the same location.
3. Signal reception may be affected by the position, height and angle of devices. If reception video is not stable, please physically adjust placement for the optimized signal.
4. Set the antennas straight up and set receiver higher to enhance the transmission efficiency.
5. The product offers the AES 128-bit encryption to protect the wireless transmission. Please still be aware of the intentional signal interception from third person. Do not use it for important communication.

## 3. Appearance Instruction

### Transmitter FLOW10K

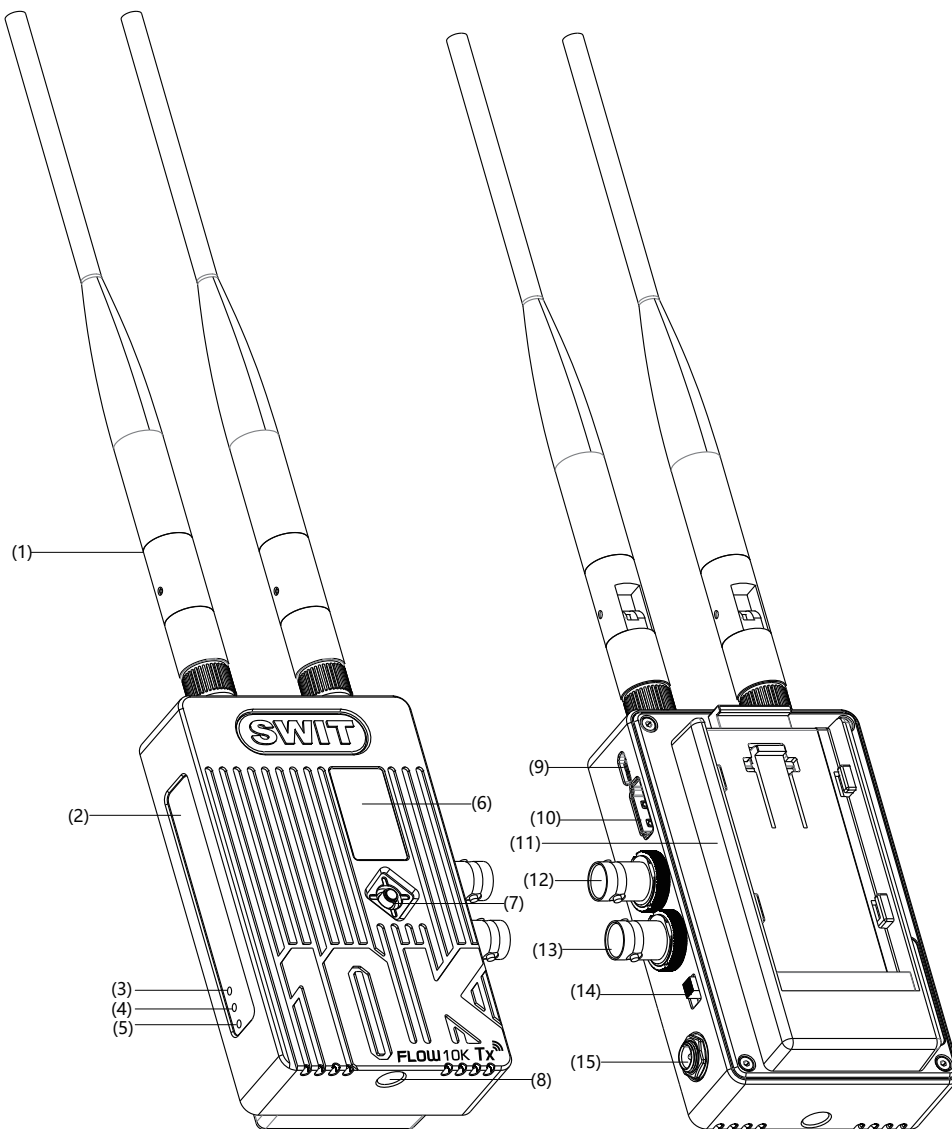

- (1) **Antenna**
- (2) **Product label**
- (3) **Link**: Wireless status indicator.
- (4) **Video**: Video signal indicator.
- (5) **Power**: Power status indicator.
- (6) **OLED display screen**: 0.96 inches OLED.
- (7) **Joystick**: Five-direction adjust button. (up, down, left, right, vertical five direction for menu adjusting and confirm.)
- (8) **Installation thread**: 1/4" -20 thread. Use the package supplied articulating arm trestle to install the device to the camera.
- (9) **USB**: Micro USB, firmware upgrade interface.
- (10) **HDMI in**: HDMI signal input, standard HDMI-A interface.
- (11) **Battery plate**: Power supply via D & F & U model battery plate. Model D battery we recommend SWIT battery: S-8D98, S-8D58, S-8D62 which is compatible with Panasonic CGA series: CGA-D54S/D28S, VBD series SVW-VBD58; Model F battery we recommend SWIT battery: S-8972, S-8970, S-8770, S-8975, which is compatible with SONY L series NP-F770/970; Model U battery we recommend SWIT battery LB-SU98, which is compatible with PXW-FX series BP-U60/U30/U90.
- (12) **SDI LOOP**: SDI signal loop out, standard BNC interface.
- (13) **SDI in**: SDI signal input, standard BNC interface.
- (14) **ON/OFF**: Power switch.
- (15) **DC in**: Support 7~34V wide voltage input.  
DC power input interface, 5.5mm (Outer diameter) /2.1mm (Inner diameter), The polarity is inner positive and outer negative.

State indicator light			
Device	Indicator	Status	Description
FLOW10K Transmitter	Power	Constant On	Power connected and switched on
		Off	Power disconnected and switched off
	Video	Constant On	There is recognizable video signal input
		Flash	There is no recognizable video signal input
	Link	Constant On	The wireless network connection is normal
		Flash	The wireless network connection is abnormal

## Receiver FLOW10K

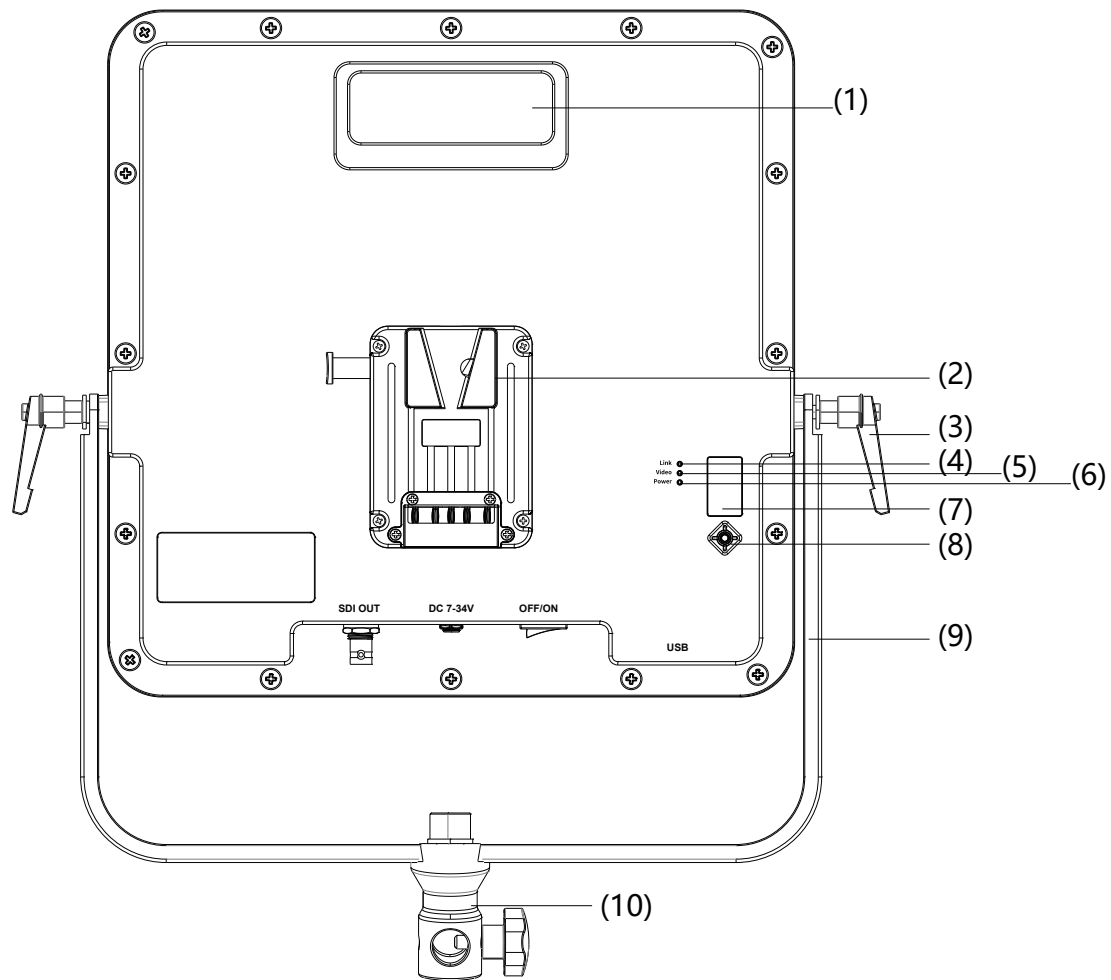

- (1) **Handle**
- (2) **Battery plate**: Power supply via V-mount battery. V-mount battery we recommend SWIT battery: :PB-M98S、PB-S98S、PB-S220S.
- (3) **Adjustable tightening handle**
- (4) **Link**: Wireless status indicator.
- (5) **Video**: Video signal indicator.
- (6) **Power**: Power status indicator.
- (7) **OLED display screen**: 0.96 inches OLED.
- (8) **Joystick**: Five-direction adjust button. (up、down、left、right、vertical five direction for manu adjusting and confirm.)
- (9) **Frame**
- (10) **Bottom bracket**

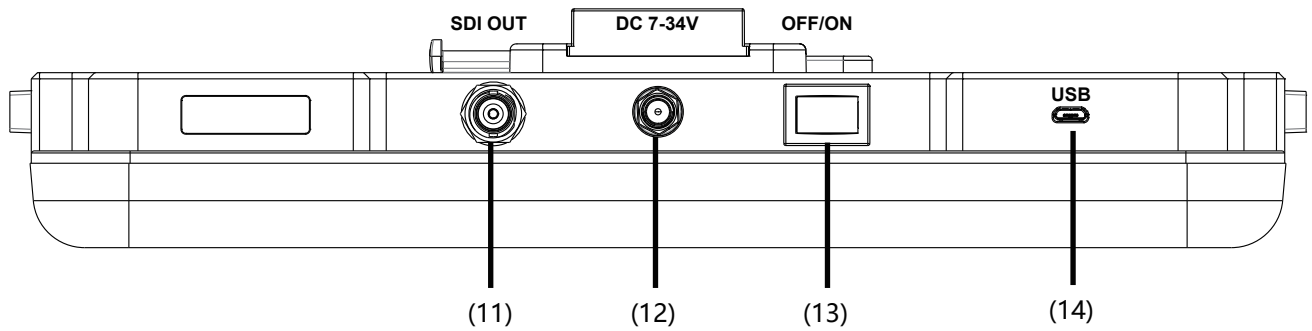

- (11) **SDI OUT**: SDI signal output, standard BNC interface.
- (12) **DC in**: Support 7~34V wide voltage input.  
DC power input interface, 5.5mm (Outer diameter) / 2.1mm (Inner diameter), The polarity is inner positive and outer negative.
- (13) **OFF/ON**: Power switch.
- (14) **USB**: Micro USB, firmware upgrade interface.

State indicator light			
Device	Indicator	Status	Description
FLOW10K Receiver	Power	Constant On	Power connected and switched on
		Off	Power disconnected and switched off
	Video	Constant On	There is recognizable video signal input
		Flash	There is no recognizable video signal input
	Link	Constant On	The wireless network connection is normal
		Flash	The wireless network connection is abnormal



## 4.OLED Display menu

### Initial interface (One-to-one mode)

When no signal input, the transmitter is consistent with the receiver display content. See Fig. 1

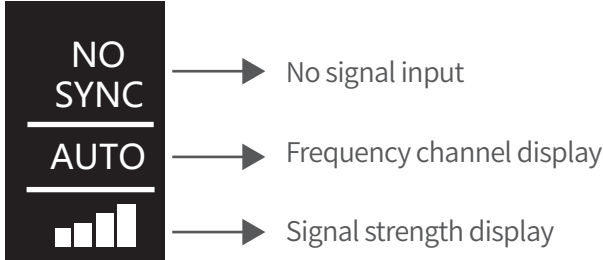

Fig. 1

### Initial interface (One-to-one mode)

When Transmitter and receiver video signal connection normal, the transmitter is consistent with the receiver display content. See Fig. 2

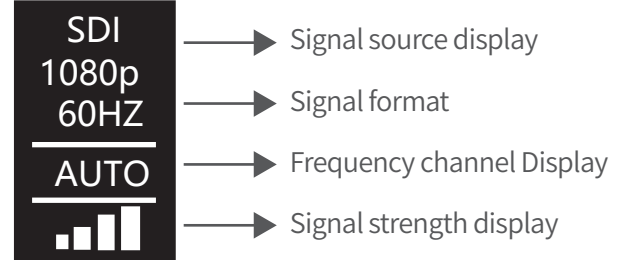

Fig. 2

### Initial interface (One-to-multi mode)

When the transmitter has no signal input, see Fig. 3

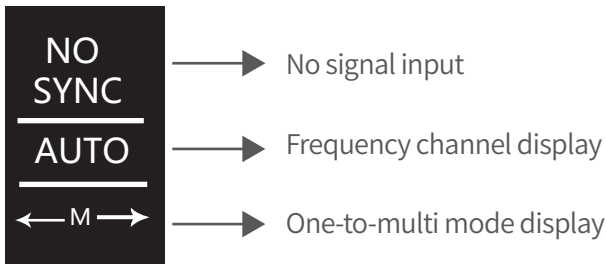

Fig. 3

### Initial interface (One-to-multi mode)

When the transmitter video signal is connected normally, as shown in Fig. 4

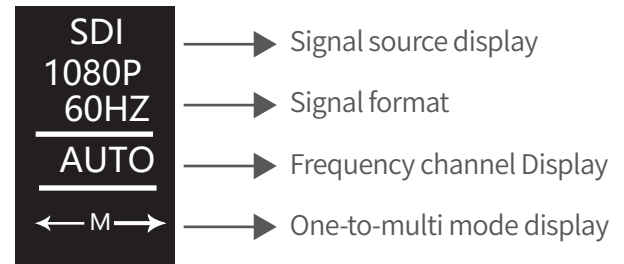

Fig. 4

### Initial interface (One-to-multi mode)

When the receiver has no signal input, see Fig. 5

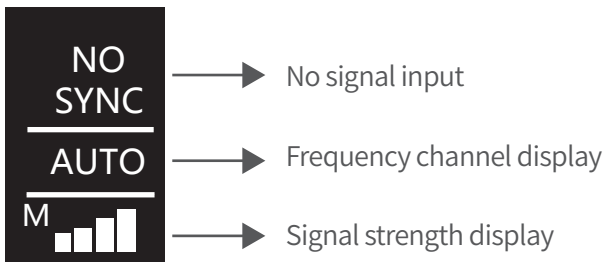

Fig. 5

### Initial interface (One-to-multi mode)

When the receiver video signal is connected normally, as shown in Fig. 6

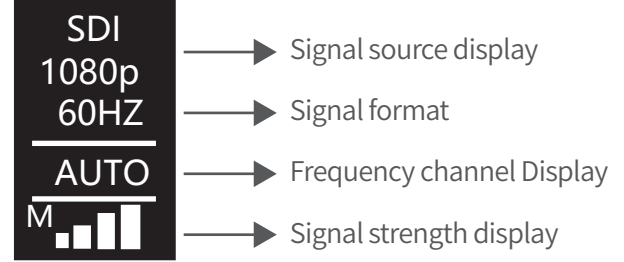

Fig. 6

#### Tips:

1. Using joystick(up and down) to change frequency channel, 7 channel in total.
2. After changing to One-to-multi mode, There will be a "M" show on the bottom

## Interface changing

a : Changing interface in transmitter via using joystick(left and right),see fig .7、8、9.

b : Changing interface in receiver via using joystick(left and right),see fig .7、9.

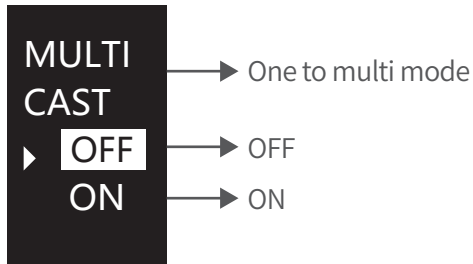

Fig.7

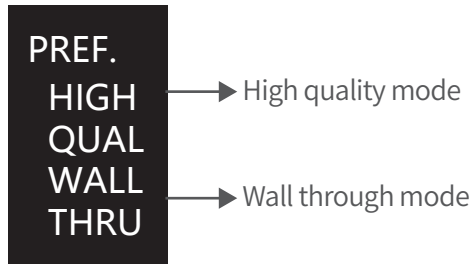

Fig.8

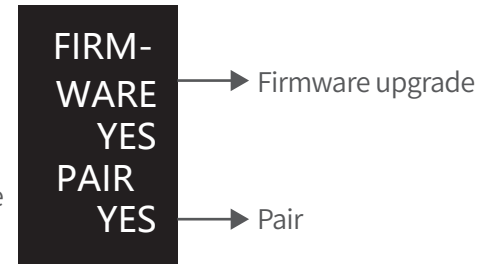

Fig.9

### Tips:

1. The menu content of transmitter and receiver is different: Quality mode and wall through mode can only be selected in transmitter, see fig.8
2. The "MULTI CAST" should change to "ON" in both transmitter and receiver to open one-to-multi mode.(Both transmitter and receiver need to choose "MULTI CAST ON")
3. Support firmware upgrading via USB interface.
4. Both transmitter and receiver support manually switch frequency channel.
5. Factory setting is "MULTI CAST OFF".
6. Choose "MULTI CAST ON" (The transmitter need to pair with every receiver before using one-to-multimode)

## 5. Pairing

- (1) Switch on both FLOW10K transmitter and receiver; The "POWER" indicator light in every receiver should light up when there are multiple receiver, Waiting for jumping to main interface.
- (2) Right pushing the joystick to "PAIR" interface and choose "YES" in both transmitter and receiver, the "LINK" indicator flashing quickly during pairing(Every receiver should pair with the transmitter separately when using one-to-multi mode) .
- (3) "LINK" indicator will stop flashing after pairing successful. Device in encrypted transmission state.

### Tips:

1. Transmitter and receiver should pair in the same time. Every receiver should pair with the transmitter separately when using one-to-multi mode.
2. Make sure every receiver have already paired successful before using one-to-multi mode.
3. The paired receiver and transmitter, automatically connected after boot, no need to pair again.
4. Keep 1-2 m distance between transmitter and receiver when pairing to avoid pairing failure.
5. Do not using more than 4 group wireless transmission device to avoid disturbing.

A screenshot of a menu titled "FIRM-WARE YES PAIR YES". It has two options: "Firmware upgrade" (indicated by a right-pointing arrow) and "Pair" (indicated by a right-pointing arrow).

Fig.10

## 6.Connection

- (1) Connecting SDI IN/HDMI IN interface of FLOW10K transmitter with SDI OUT/HDMI OUT interface of camera or video output device. Connecting SDI loop out interface of FLOW10K transmitter with SDI IN interface of monitor or switcher.

- (2) Connecting SDI OUT interface of FLOW10K receiver with SDI IN interface of monitor or switcher.  
When using one-to-multi mode, every SDI OUT interface of receiver should be connected with SDI IN interface of monitor or switcher.
- (3) Switch on both FLOW10K transmitter and receiver, “Power” indicator light up, OLED screen show “WAIT...” then jump to initial interface, see fig.1 or fig.3; Wait until “Link” and “Video” indicator light up, the transmitter and receiver have identifiable signal inputs and connected successfully. If the transmitter and receiver have identifiable signal inputs but fail to establish a connection, the "link" indicator will flash.

**Tips:**

1. After powering the FLOW10K transmitter and receiver, dial the power switch on the product to "on"
2. FLOW10K transmitter support SDI video signal input and HDMI video signal input, The system automatically identify input video interfaces.  
System will choose SDI video signal when both HDMI and SDI interface is connected.
3. When multiple receivers are used simultaneously in the same environment, ensure that multiple wireless devices have identifiable signal input.

## 7.High quality mode & Wall through mode

- (1) Connecting SDI IN/HDMI IN interface of FLOW10K with SDI OUT/HDMI OUT interface of camera or video output device.  
Connecting SDI loop out interface of FLOW10K transmitter with SDI IN interface of monitor or switcher.
- (2) When using one-to-multi mode, every SDI OUT interface of receiver should be connected with SDI IN interface of monitor or switcher.
- (3) Switch on both FLOW10K transmitter and receiver, every receiver should be switch on when using one-to-multi mode.  
“Power” indicator light up, OLED screen show “WAIT...” then jump to initial interface, see fig.1 or fig.3; Wait until “Link” and “Video” indicator light up, the transmitter and receiver have identifiable signal inputs and connected successfully, right push the joystick to “PREF” interface, see fig.11.
- (4) It is recommended to choose high quality mode for wireless devices under normal operating conditions, such as better environment, stronger signal, or more than one set of wireless devices under the same scene.
- (5) Wall through mode is recommended for wireless devices under complex operating conditions, such as poor on-site environments, high distance barriers and only 1-2 sets of wireless devices in the same scene. (If more than one set is used in the same scene, it is recommended to use a high quality mode to reduce interaction)

**Tips:**

1. When wireless devices under normal operating condition, choose High quality mode can get a better video quality, but transmission distance will be cut.
2. When wireless devices under complex operating condition, choose Wall through mode can get a long transmission distance, but the video quality will be cut.

PREF.  
HIGH  
QUAL  
WALL  
THRU

Fig. 11

## 8. The way to get the best effective of Wireless Transmission

- (1) Set the antenna on both transmitter and receiver vertically straight up. (See Fig.12), Set the receiver faces the transmitter to extend the transmission distance and stabilize the transmission quality.

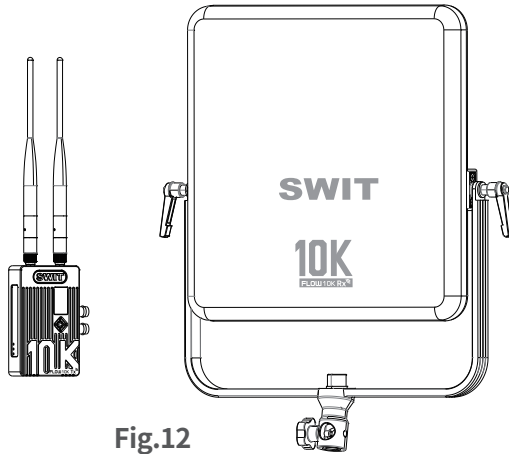
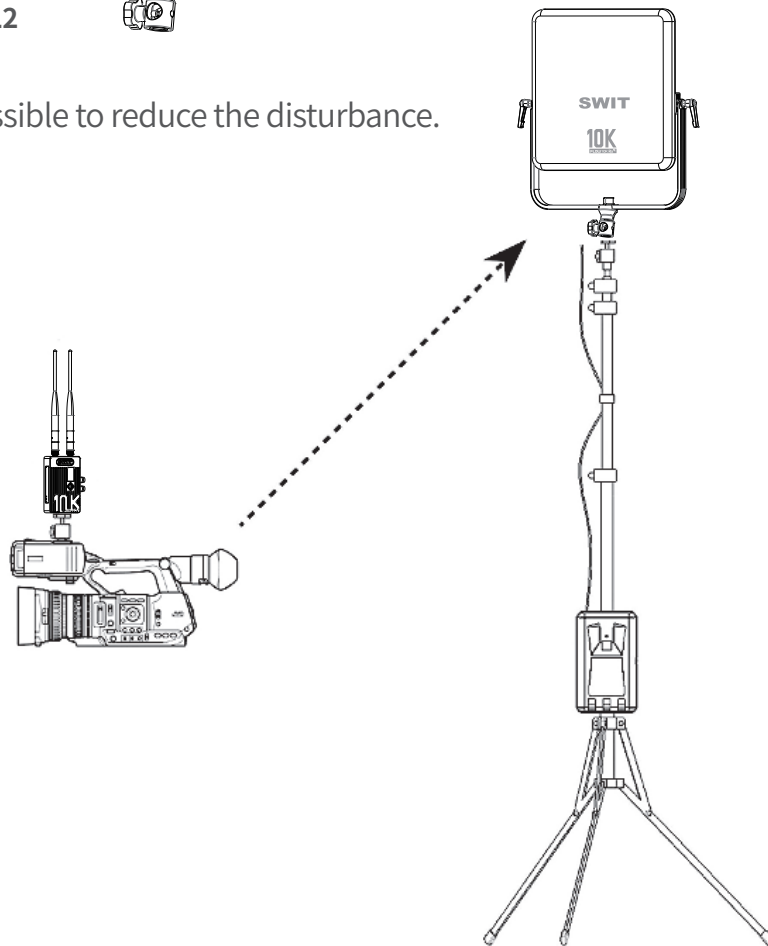

Fig.12

- (2) Put the receiver as high as possible to reduce the disturbance.



- (3) Avoid walls, trees and water to reduce signal attenuation.



## 9. Trouble shooting

If the receiver failed to output video correctly, the possible causes are as below; please find the solution from following chart:

The receiving video	Possible causes	Solution
No display	The transmitter or the receiver Is not powered on	Check power connection and switch on the transmitter and receiver
	The antennas are not installed properly and screwed tightly	Install the antennas properly and screw tightly of both transmitter and receiver
	Bad connection of video cable	Check video cable connection of both transmitter and receiver
	Video format is not supported	Change the output video format of the camera
Poor Video quality	Bad connection with video cable	Reconnect reliably
	The wireless transmission is disturbed by environment	Wait for 1 minute or reboot the transmitter and receiver
	The transmission distance is out of effective	Put the transmitter closer to the receiver

## 10. Specification

Model	FLOW10K Transmitter	FLOW10K Receiver
Input	SDI×1、HDMI×1	/
Output	SDI×1	SDI×1
Video format	1080I (60/59.94/50) /1080PsF (24/23.98) /720P (60/59.94/50)/1080P (60/59.94/50/30/29.97/25/24/23.98)	
Wireless frequency	5180~5220MHz and 5760~5820MHz	
modulation mode	OFDM Support 16QAM, 64QAM, QPSK, BPSK modulation mode	
transmission distance	3000m (Line of sight)	
Power consumption	≤9W	≤9W
operation	0.96 inches OLED display screen, five-direction adjust button	
Input voltage	DC/ Battery:7~34V	DC/ Battery :7~34V
Working environment	Temperature :0°C~+40°C	
Dimension(without antenna and plate)	66×106.5×24.7 (mm)	190×190×46 (mm)
Net weight (With antenna and rack)	286g	1500g